

DOCK SYSTEM

Dock Ladder

3 Step 49" Galvanized #28273 / Painted #27273

4 Step 60" Galvanized #28274 / Painted #27274

5 Step 71" Galvanized #28275 / Painted #27275

Tools Required:

Flat head screwdriver, Phillips head screwdriver, 7/16" wrench, hand or power drill, and a 1/4" drill bit.

IMPORTANT:

Ladder will fall into water if not bolted to the dock. Be careful when using ladder to mark holes. Set ladder completely on top of the dock after using to mark the holes to be drilled.

Assembly Instructions

1. Using the drawing as a guide, place the ladder side rails parallel to each other with a step between them. Attach steps, dimple side up, using 4-1/4" x 3/4" stove bolts per step. Step end should overlap mounting bracket on side rails.

DO NOT TIGHTEN STEP BOLTS UNTIL ALL STEPS ARE ATTACHED

2. Before attaching the ladder to the dock, check for obstructions under the dock where the bolt holes will be drilled. Should you leave a floating dock, make sure the ladder will not be damaged in fluctuating water levels. To mark the holes use the ladder as a template. The ladder should be flush against the top side of the dock. Drill four holes using your 1/4" drill bit. Attach ladder to dock with four 1/4" x 4" stove bolts.

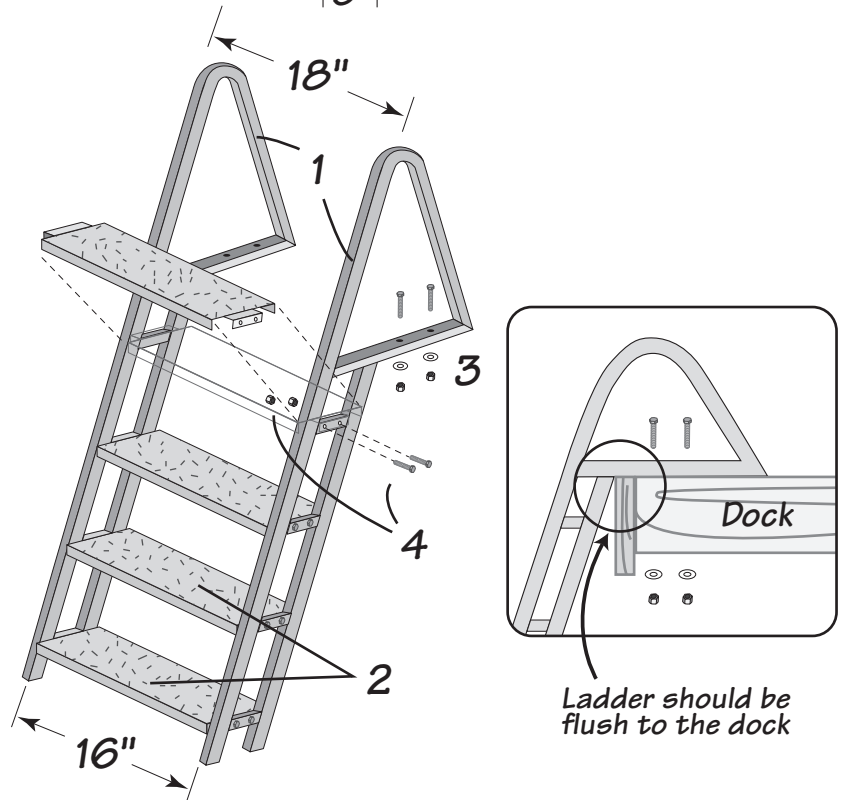
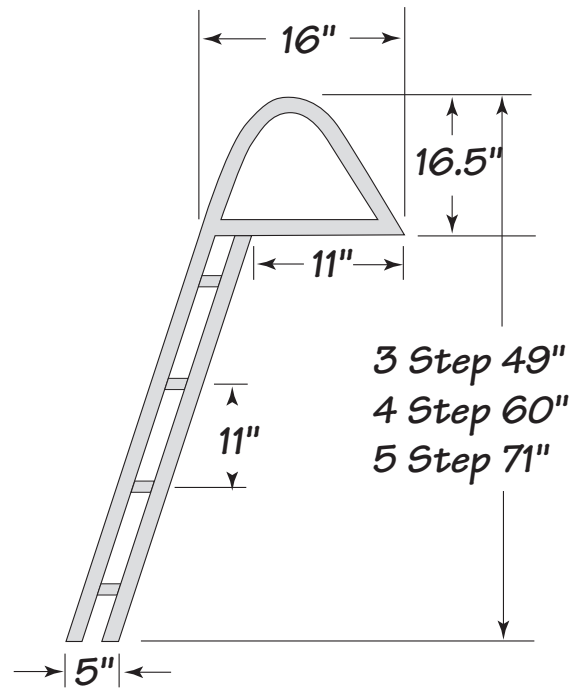

Item #	Description	3 Step	4 Step	5 Step
1	Side Rail	2	2	2
2	Step with dimples	3	4	5
3	1/4" x 4" Stove bolt, flat washers and nuts	4	4	4
4	1/4" x 3/4" bolts and nuts	12	16	20

Instruction Part #15361

TIE DOWN ENGINEERING • 5901 Wheaton Drive • Atlanta GA, 30336
www.tiedown.com • (404) 344-0000 • Fax (404) 349-0401

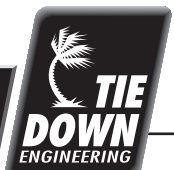

073107,a604

DOCK SYSTEM

Speed Release

(Purchased Separately)

Part #27271

Used with Tie Down's Dock Ladder:

3 Step 49" Galvanized #28273 / Painted #27273

4 Step 60" Galvanized #28274 / Painted #27274

5 Step 71" Galvanized #28275 / Painted #27275

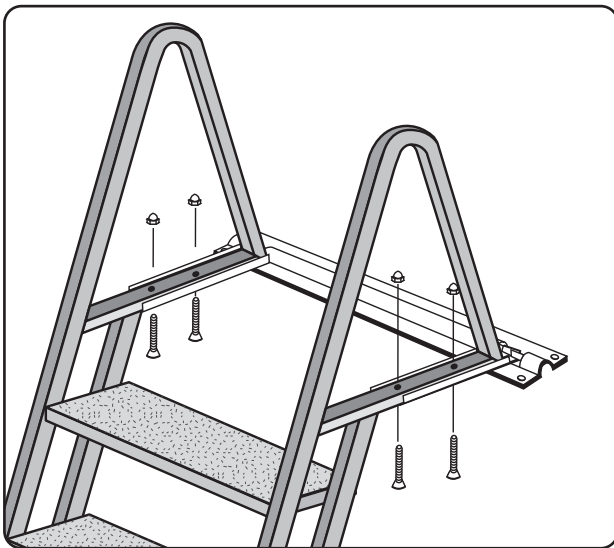

TOOLS REQUIRED

Flathead screwdriver, 7/16" wrench, hand or power drill, and a 1/4" drill bit.

ASSEMBLY INSTRUCTIONS

1. Attach the Speed Release side plates under the bottom of the ladder braces as shown in the picture, using the 1/4" x 1-1/2" Phillips flat head screws and acorn nuts. Acorn nuts are used on the top. Make sure that the side flanges are located to the outside edge of the ladder brace. Do not tighten at this time. Using the Speed Release base as a guide, make sure the tabs are centered in the base openings. Now tighten the acorn nuts.

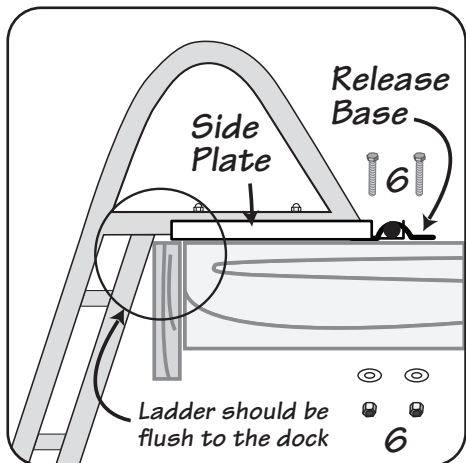

Speed Release/Dock Placement

2. Before attaching the ladder to the dock, check for obstructions under the dock where the bolt holes will be drilled. Should you have a floating dock, make sure the ladder will not be damaged in fluctuating water levels. The ladder should be flush against the top side of the dock with the Speed Release base attached to the ladder. To mark the holes, use the base plate as a template. Drill four holes using your 1/4" drill bit. Attach ladder to dock with the four 1/4" x 4" stove bolts furnished in the Dock Ladder hardware bag.

IMPORTANT:

LADDER WILL FALL INTO WATER IF NOT BOLTED TO THE DOCK. BE CAREFUL WHEN USING LADDER TO MARK HOLES. SET LADDER COMPLETELY ON TOP OF DOCK AFTER USING TO MARK THE HOLES TO BE DRILLED.

Item #	Description	Qty
1	Speed Release Base	1
2	Speed Release Side Plate Left	1
3	Speed Release Side Plate Right	1
4	1/4" x 1-1/2" Phillips Flat Head Screw	4
5	Acorn Nut	4
6	1/4" x 4" Stove bolt, flat washer & Nut	NA

Furnished in Dock Ladder Hardware Bag

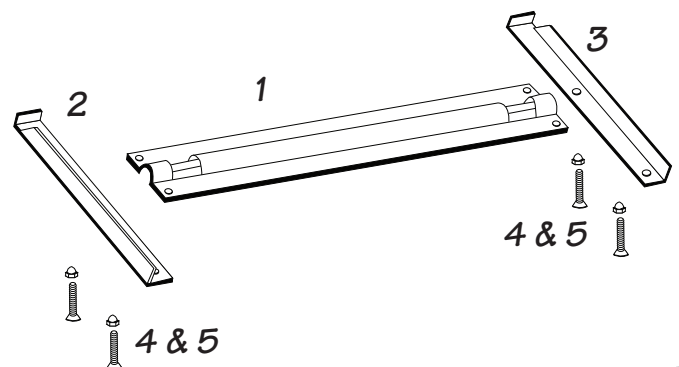

Instruction Part #15360

TIE DOWN ENGINEERING • 5901 Wheaton Drive • Atlanta, GA 30336
www.tiedown.com • (404) 344-0000 • Fax (404) 349-0401

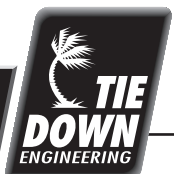

073107_a709